

ACR03F Series

Features

- 60A switching capability
- 1 Form A & 1 Form C contact arrangement
- Coil voltage: 6~72VDC
- Various mounting terminations available
- Plastic sealed and dust protected types available

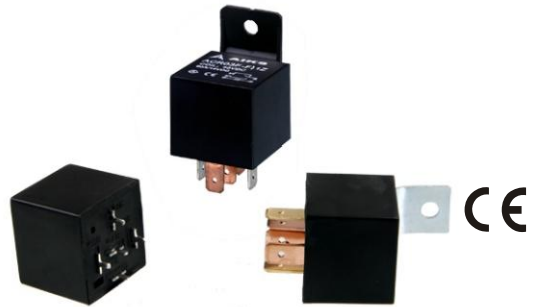

► CONTACT DATA

Contact arrangement	1A	1C
Contact Resistance	100mΩ (1A 24 VDC)	
Contact material	AgCdO, AgSnO ₂	
Contact rating(Res.load)	80A 14VDC	NO 80 A 14VDC NC 70 A 14VDC
Max.switching power	1120W	
Max.switching voltage	30VDC	
Max.switching current	80A	
Mechanical endurance	1×10 ⁷ OPS	
Electrical endurance	1×10 ⁵ OPS	

► CHARACTERISTICS

Insulation resistance	100MΩ (500VDC)	
Dielectric strength	Between coil & contacts	750VAC 1 min
	Between open contacts	500VAC 1min
Operate time(at nomi.volt)	10ms max.	
Release time(at nomi.volt)	10ms max.	
Shock resistance	Functional	98m/s ²
	Destructive	980m/s ²
Vibration resistance	10Hz ~55Hz 1.5mm DA	
Humidity	98% RH,40℃	
Ambient temperature	-55℃ ~85℃	
Termination	QC,PCB Terminal	
Unit weight	Weather-proof cover:Approx.55g Others:Approx.35g	
Construction	Plastic Sealed,Dust protected	

► **COIL DATA** at 23°C

	Nominal Voltage VDC	Pick-up Voltage VDC	Drop-out Voltage VDC	Coil Resistance $\times (1 \pm 10\%) \Omega$	Parallel resistance ²⁾ $\times (1 \pm 5\%) \Omega$	Equivalent resistance Ω	Power consumption W	Max. allowable overdrive Voltage ¹⁾ VDC	
								23 °C	85 °C
Weather-proof cover	6	3.6	0.6	22	---	---	1.6	10.1	7.9
	6	3.6	0.6	22	180	19.6	1.8	10.1	7.9
	12	7.2	1.2	90	---	---	1.6	20.2	15.7
	12	7.2	1.2	90	680	79.5	1.8	20.2	15.7
	24	14.4	2.4	360	---	---	1.6	40.5	31.5
	24	14.4	2.4	360	2700	317.6	1.8	40.5	31.5
Others	6	3.9	0.6	22	---	---	1.6	10.1	7.9
	6	3.9	0.6	22	180	19.6	1.8	10.1	7.9
	12	7.8	1.2	85	---	---	1.7	20.2	15.7
	12	7.8	1.2	85	680	75.6	1.9	20.2	15.7
	24	15.6	2.4	350	---	---	1.6	40.5	31.5
	24	15.6	2.4	350	2700	309.8	1.9	40.5	31.5

► **MODEL DESCRIPTION**

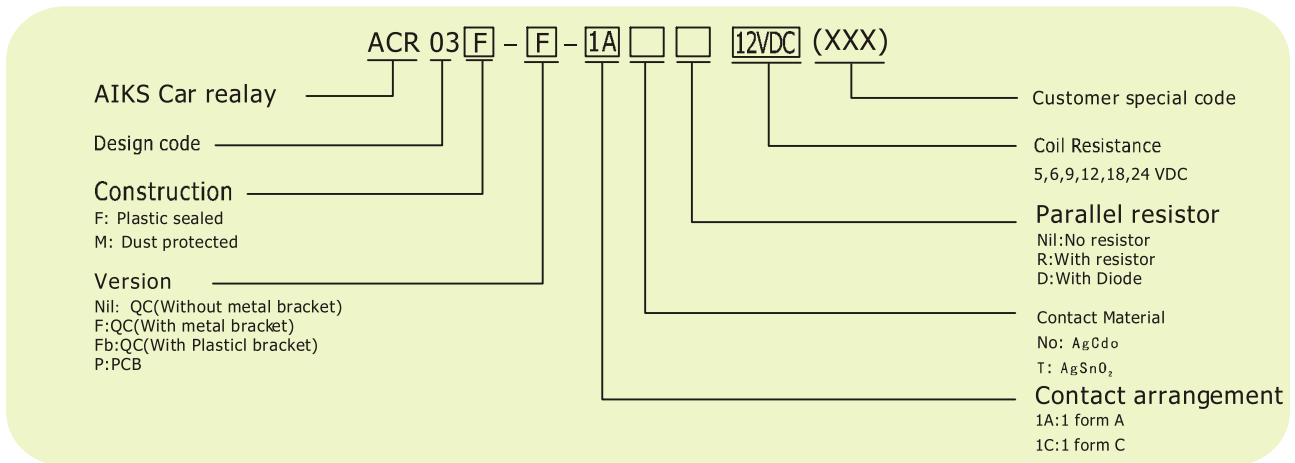

► **OUTLINE DIMENSIONS, WIRING DIAGRAM AND PC BOARD LAYOUT**

Unit: mm

ACR03F

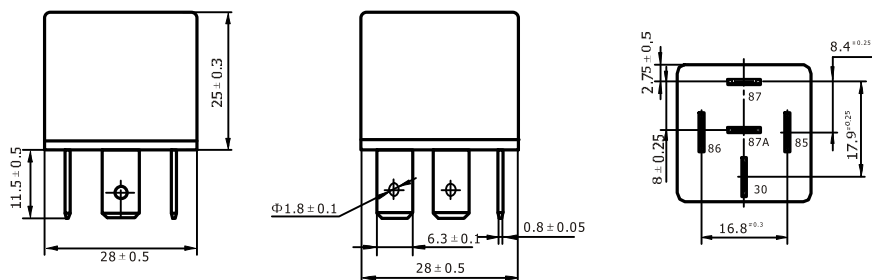

▶ OUTLINE DIMENSIONS, WIRING DIAGRAM AND PC BOARD LAYOUT Unit: mm

ACR03F-P

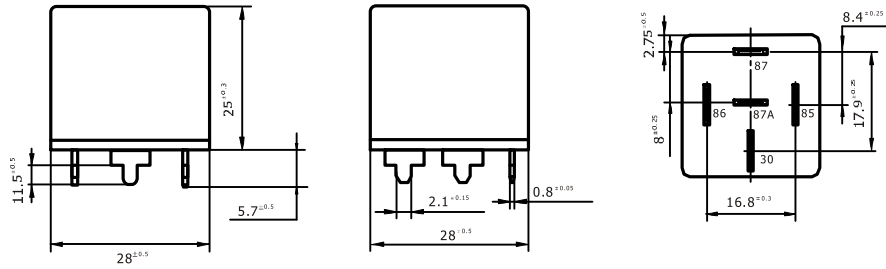

ACR03F-Fb

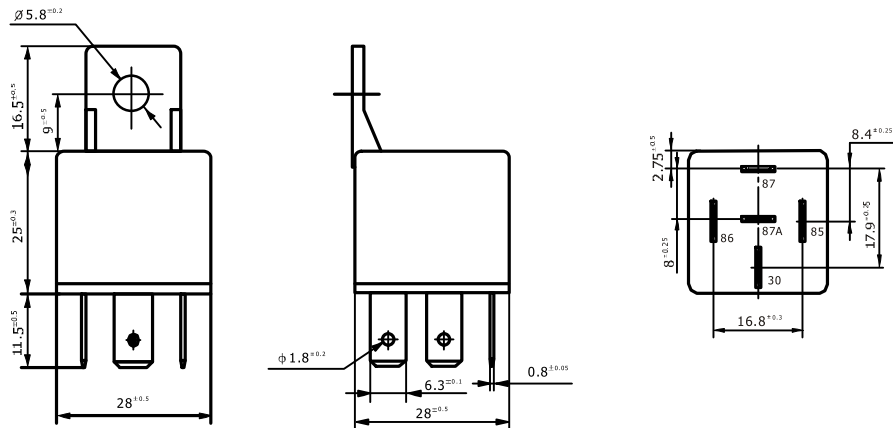

ACR03F-F

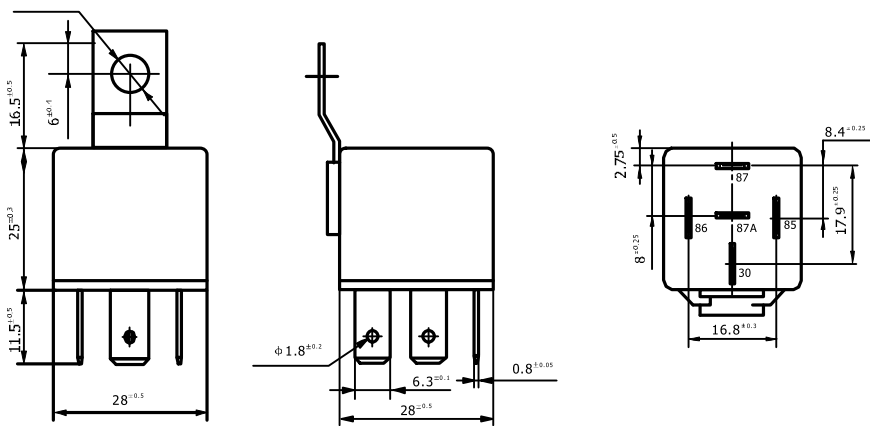

1 Form A

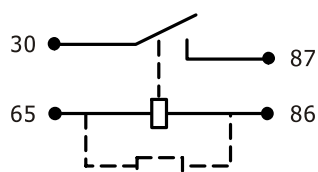

1 Form C

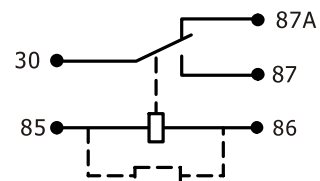

Remark: 1) In case of no tolerance shown in outline dimension: outline dimension ≤ 1 mm, tolerance should be ± 0.2 mm; outline dimension > 1 mm and ≤ 5 mm, tolerance should be ± 0.3 mm; outline dimension > 5 mm, tolerance should be ± 0.4 mm
2) The tolerance without indicating for PCB layout is always ± 0.1 mm..

► Characteristic curves

